



PanelPC-G101X - 11G

Made in ITALY

- 10,1" Industrial Glass Frame Panel PC (16:10)
- Intel Tiger Lake UP3 - i5 1135G7E
- Up to 64GB RAM
- WXGA (1280x800) resolutions
- Aluminum + Glass Frame front panel
- Projective Capacitive Multitouch - 10 points
- 2x GbE (1x 2.5G)+ 2x DP + 2x HDMI + 4x USB 3.2 + 2x RS232/422/485 + 1x RS232
- 12 ~ 24 VDC w/ Terminal Block 3P or 220 VAC w/ IEC connector + Remote ON/OFF
- Panel and VESA Mount



MAINBOARD

CPU: Intel Tiger Lake-UP3 i5 1135G7E
4 Core / 8 Thread
1.5 GHz (Base) / 4.1 GHz (Turbo) 15W

MEMORY

Capacity: up to 64GB
Frequency: 3200 MHz
Type: 2x SO-DIMM DDR4

STORAGE

SATA: 1x SATA3
M.2: 1x M.2 M-Key (2242/2260/2280)
Support NVMe
Storage Bay: 1x Internal 2.5" SSD Bay

I/O INTERFACE

Serial ports: 2x COM RS232/422/485
2x COM RS232
USB ports: 4x USB 3.2
M.2: 1x M.2 E-Key (2230)
1x M.2 B-Key (3042)
AUDIO: 1x Line-out Combo Jack

VIDEO

GPU: Intel Iris Xe Graphics
Interface: 2x HDMI 2.0b (Up to 4096x2160 @60Hz)
2x DP 1.4 (4096 * 2304 @ 60Hz)

ETHERNET

LAN: 1x Intel i225V 2.5GbE Gigabit LAN
1x Intel I219-LM PHY Gigabit LAN

DISPLAY

Size: 10,1"
Resolution: WXGA (1280x800)
Aspect Ratio: 16:10
Backlight: Led
Bright and Contrast: 500 cd/mq 800:1
Colors: 16 M
View Angle: 170° - 170°

TOUCH SCREEN

Glass Thickness: 2 mm
Technology: Projective Capacitive Multitouch

FRONT PANEL

Thickness: 6 mm
Front Panel Type: Aluminum + Glass Frame

*All product information may subject to change without prior notice.

*The rights of all brand names, product names and trademarks belong to their respective owners.

SARC ITALIA SRL

Strada Albareto, 503 - 41122 Modena - ITALY
Tel. +39 059 8751076 Fax. +39 059 8751025

Website: www.indatech.it

Email: info@indatech.it

Copyright © 2024 INDATECH. All rights reserved.

INDATECH®

MECHANICAL

Material:	Aluminum + Steel
IP Protection:	IP65 on front side
Dimensions:	(W)280x(D)200x(H)92,6mm
Weight:	3 Kg
Mounting:	Panel Mount / VESA 100

ENVIRONMENT

Operating temp.:	0°C ~ 60°C
Storage temp.:	-20°C ~ 70°C
Humidity:	40% ~ 60% Humidity, non-condensing
EMC:	CE, RoHS

POWER

Power in:	12 ~ 24 VDC or 220 VAC
Max Power:	~60 W max
Connector:	Terminal Block 3P or IEC connector

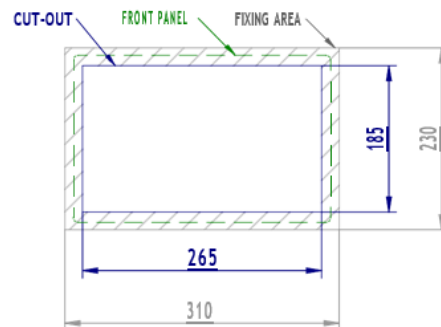
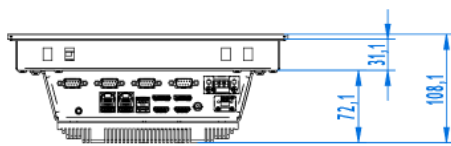
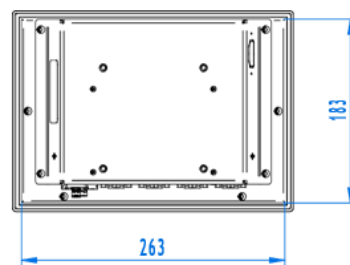
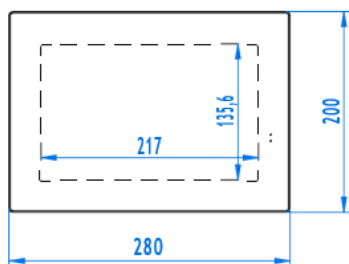

ACCESSORIES INCLUDED:

- Fast clamp Mounting Kit

COMPATIBLE OS:

MS WINDOWS (64bit)

- Windows 10
- **Windows 10 Enterprise LTSC (IoT)**
- Windows 11
- Windows 11 Enterprise LTSC (IoT)



LINUX *

- CentOS 8
- Debian 10
- Fedora 34
- Ubuntu 20.04 LTS
- pfSense



* Linux distributions tested with the IPC.

ORDER CODE:

Contact your sales representative for configuration.

*All product information may subject to change without prior notice.

*The rights of all brand names, product names and trademarks belong to their respective owners.

SARC ITALIA SRL

Strada Albareto, 503 - 41122 Modena - ITALY
Tel. +39 059 8751076 Fax. +39 059 8751025

Website: www.indatech.it

Email: info@indatech.it

Copyright © 2024 INDATECH. All rights reserved.